

Sports exhaust system (OP8)

Situation: **Retrofitting**

Model Year: **As of 2011 up to 2014**

Engine Type: 5502 = V6/3.6 litre/220 kW (299 hp) – Cayenne
4802 = V8/4.8 litre/294 kW (399 hp) – Cayenne S

Restrictions: **NOT** approved for Korea (country code C39) and Japan (C08/C18)!

Cayenne (5502 = V6/3.6 litre/220 kW (299 hp)):

- **NOT** approved for USA/Puerto Rico (C02) and Canada (C36)!
- **NOT** approved for vehicles with manual transmission!

Note: Up to model year 2013, the sports exhaust system is activated and deactivated by pressing the "Sport" button.

From model year 2014 onwards, the sports exhaust system is activated and deactivated using the new strip for switches with the additional "Twin tailpipe" button. The sports exhaust system is also activated by pressing the "Sport" button. The sports exhaust system can be switched off separately in this mode by pressing the "Twin tailpipe" button.

The strip for switches must also be ordered. The strip for switches **cannot** be used in model year 2013 vehicles.

Engine power and exhaust behaviour of the vehicle are not affected. The sports exhaust system is also available ex-works for new vehicles by requesting optional equipment "OP8".

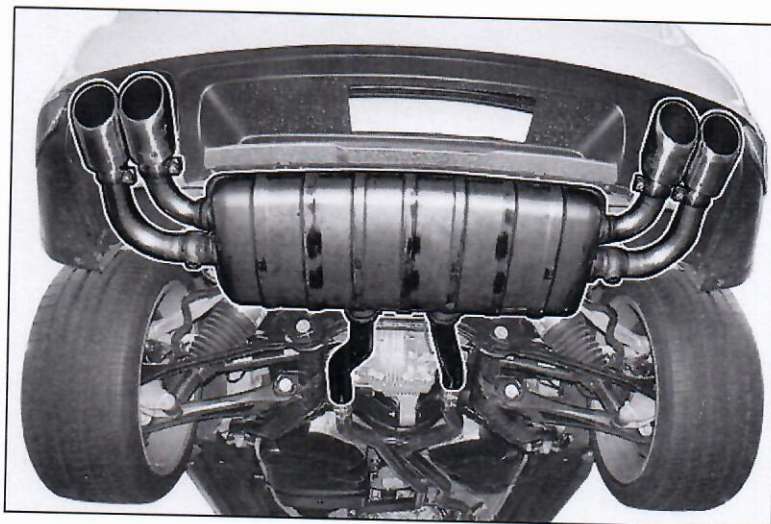

Figure 1

Part Nos.: **958.044.200.00**
958.044.200.01

⇒ Sports exhaust system – set for Cayenne
 ⇒ Sports exhaust system – set for Cayenne S

Information on ordering: For vehicles from model year 2014 onwards, also order the strip for switches (keypad). The illustration and table make ordering easier.

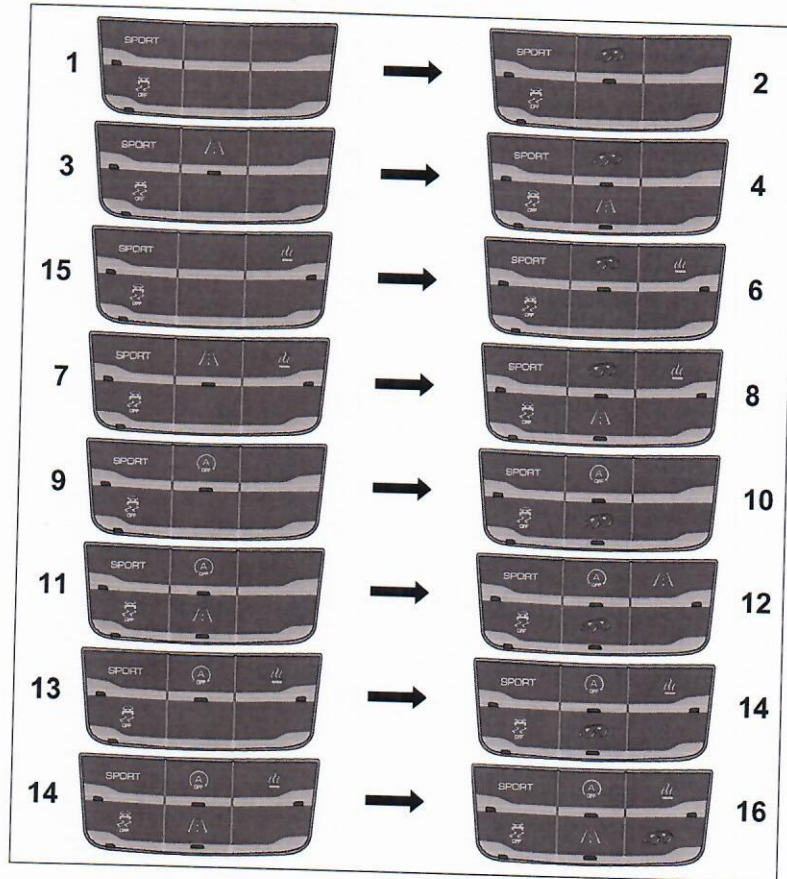

Figure 2

Installed strip for switches			Required strip for switches		
	Part No.	I-no.		Part No.	I-no.
1	958.613.140.00	OK0/OP0/OP3 7L7/7Y0/7Y1 9M09M5	2	958.613.149.00	OK0/OP8/OP9 7L7/7Y0/7Y1 9M0/9M5
3	958.613.157.00	OK0/OP0/OP3 7L7/7Y6/7Y7 9M0/9M5	4	958.613.148.00	OK0/OP8/OP9 7L7/7Y6/7Y1 9M0/9M5
5	958.613.256.00	OK0/OP0/OP3 7L7/7Y0/7Y1 9M1/9M9	6	958.613.147.00	OK0/OP8/OP9 7L7/7Y0/7Y1 9M1/9M9

7	958.613.155.00	OK0/OP0/OP3 7L7/7Y6/7Y7 9M1/9M9	8	958.613.146.00	OK0/OP8/OP9 7L7/7Y6/7Y7 9M1/9M9
9	958.613.153.00	OK0/OP0/OP3 7L4/7L8/7Y0 7Y1/9M0/9M5	10	958.613.144.00	OK0/OP8/OP9 7L4/7L8/7Y0 7Y1/9M0/9M5
11	958.613.152.00	OK0/OP0/OP3 7L4/7L8/7Y6 7Y7/9M0/9M5	12	958.613.143.00	OK0/OP8/OP9 7L4/7L8/7Y6 7Y7/9M0/9M5
13	958.613.151.00	OK0/OP0/OP3 7L4/7L8/7Y0 7Y1/9M1/9M9	14	958.613.142.00	OK0/OP8/OP9 7L4/7L8/7Y0 7Y1/9M1/9M9
15	958.613.150.00	OK0/OP0/OP3 7L4/7L8/7Y6 7Y7/9M1/9M9	16	958.613.141.00	OK0/OP8/OP9 7L4/7L8/7Y6 7Y7/9M1/9M9

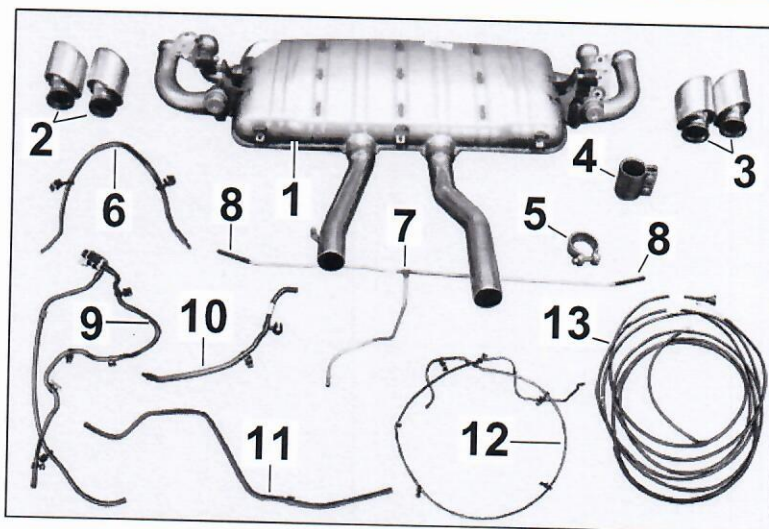

Figure 3

Parts List:	958.111.910.60 ¹	1 x	Rear silencer, 3.6 litre – Cayenne (not shown)
	958.111.910.30 ²	1 x	Rear silencer, 4.8 litre – Cayenne S ⇒ <i>Figure 3-1-</i>
	958.111.252.30	2 x	Tailpipe, right ⇒ <i>Figure 3-2-</i>
	958.111.251.30	2 x	Tailpipe, left ⇒ <i>Figure 3-3-</i>
	958.111.220.20	2 x	Clamping sleeve ⇒ <i>Figure 3-4-</i>
	958.111.240.00	4 x	Clamp (for tailpipe) ⇒ <i>Figure 3-5-</i>
	958.111.160.50 ¹	1 x	Control line for engine compartment, 3.6 litre – Cayenne ⇒ <i>Figure 3-6-</i>
	958.111.160.40	1 x	Control line for rear silencer ⇒ <i>Figure 3-7-</i>
	958.111.709.00	2 x	Vacuum hose ⇒ <i>Figure 3-8-</i>
	958.111.160.10	1 x	Control line for wheel housing ⇒ <i>Figure 3-9-</i>

958.111.160.02 ²	1 x	Control line for engine compartment, 4.8 litre – Cayenne S ⇒ <i>Figure 3-10-</i>
958.111.160.30	1 x	Control line for rear axle ⇒ <i>Figure 3-11-</i>
958.111.160.20	1 x	Control line for door sill ⇒ <i>Figure 3-12-</i>
958.044.200.04	1 x	Electric wire harness ⇒ <i>Figure 3-13-</i>
or		
958.044.200.05 ³		
N 020.904 4	20 x	Tie-wrap (not shown)
N 989 520 01	1 x	Screw, M11.113 x 1.27 x 18 (not shown)

- 1 Only contained in parts kit 958.044.200.00.
- 2 Only contained in parts kit 958.044.200.01.
- 3 Gradually replaces wire harness 958.044.200.04.

Notes:

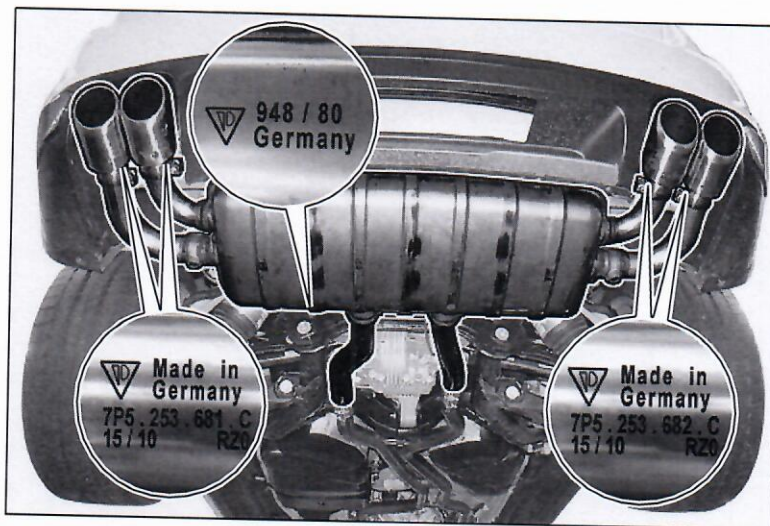

Figure 4

Identifying features when installed.

The outside of the rear silencer is marked as follows:

Cayenne/Cayenne S: Porsche logo; marking 948/80

The tailpipes are marked as follows:

Porsche logo; right tailpipe - Part No.: 7P5.253.682.C, left tailpipe - Part No.: 7P5.253.681.C

The relevant legal regulations must be observed in the various countries.

For European Union (EU) member states:

The sports exhaust system described here is contained in the EU general certification of Cayenne vehicles as of e13*2007/46*1085 and e13*2007/46*1106.

Applicable only in Germany:

The installed/added components do not have to be approved in accordance with § 19 or § 21 of the German Federal Motor Vehicle Safety Standards (StVZO) and the vehicle registration documents do

not need to be changed since the sports exhaust system specified above was approved with the vehicle ex-works. An excerpt on this topic can be retrieved from the EU type approval system in the PIWIS information system. If not, this excerpt can be requested from the PDA department of Porsche Deutschland GmbH.

This excerpt must be used by the respective Porsche Centre to confirm that the components were fitted in accordance with regulations, and must be handed over to the customer.

Materials: — — — Wrapping tape (commercially available)
 000.043.204.82 — — Adhesive sealant

Tools: **Nr. 166 - Chain-type pipe cutters**
Nr. 166-1 - Ratchet-type pipe cutters
9900 - PIWIS Tester 3
9827 - Unlocking tool

- Fitting:
- 1 Preparatory work:
 - 1.1 Connect a battery charger. ⇒ *Workshop Manual '2X00IN Battery trickle charging'*
 - 1.2 **Only** when installing wire harness 958.044.200.05:
 Remove front right headlight. ⇒ *Workshop Manual '941519 Removing and installing headlights'*
 - 1.3 Remove engine compartment trim panel at the right. ⇒ *Workshop Manual '700219 Removing and installing front trim (engine compartment)'*
 - 1.4 Unscrew fastening screw ⇒ *Figure 5 -arrow-* on the filler tube for the windscreen washer system reservoir.
 - 1.5 Remove right front wheel and right rear wheel. ⇒ *Workshop Manual '440519 Removing and installing wheel'*
 - 1.6 Remove front right wheel housing liner. ⇒ *Workshop Manual '505619 Removing and installing front wheel housing liner'*
 - 1.7 Remove rear wheel housing liner at the right. ⇒ *Workshop Manual '536919 Removing and installing rear wheel housing liner'*
 - 1.8 Remove reservoir for windscreen washer system. ⇒ *Workshop Manual '926019 Removing and installing reservoir for windscreen washer system'*
 - 1.9 Remove centre cover at the right. ⇒ *Workshop Manual '519319 Removing and installing cover for centre underbody'*
 - 1.10 Remove loudspeaker booster. ⇒ *Workshop Manual '914419 Removing and installing loudspeaker booster'*

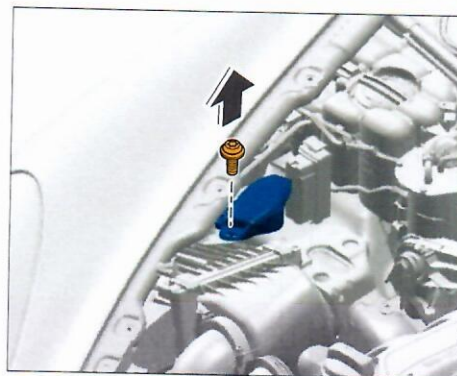

Figure 5

1.11 Remove rear silencer. ⇒ *Workshop Manual '263355 Replacing rear silencer'*

2 Install rear silencer.

2.1 Fit control line for rear silencer ⇒ *Figure 6-1-* into the rear silencer holder ⇒ *Figure 6-2-*.

Slide vacuum hoses ⇒ *Figure 6-3-* onto the vacuum unit.

Slide vacuum hose as far as it will go ⇒ *Figure 6-arrow-* onto the rear silencer control line.

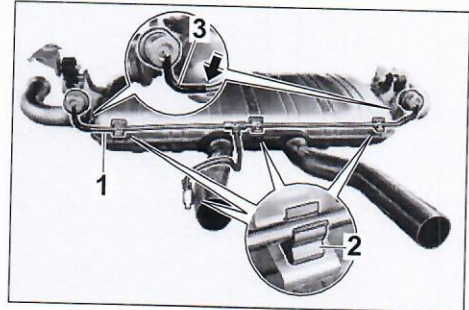

Figure 6

2.2 Pre-fit tailpipes ⇒ *Figure 7-1-* with clamps ⇒ *Figure 7-2-* on the rear silencer ⇒ *Figure 7-3-*.

Tighten clamps slightly but ensure that the tailpipe can still be moved.

2.3 Install rear silencer. ⇒ *Workshop Manual '263355 Replacing rear silencer'*

2.4 Adjust tailpipes.



Information

Use V8 Turbo adjustment dimensions!

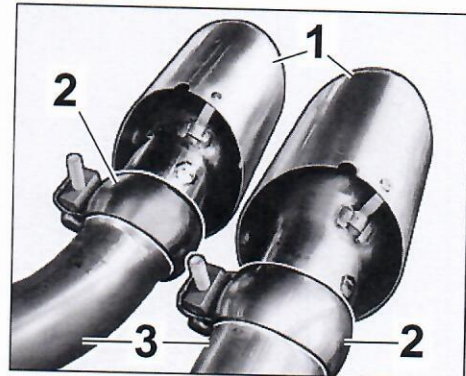

Figure 7

2.4.1 Adjust tailpipes at the left and right. ⇒ *Workshop Manual '263415 Adjusting tailpipes'*

2.4.2 Tighten tailpipe clamps.

Tightening torque 35 Nm (26 ftlb.) - 2 Nm (-1.5 ftlb.)

3 Route control lines.

3.1 Route control line for rear axle.

- 3.1.1 Route control line for rear axle
⇒ *Figure 8-1*- from the connection at the rear silencer control line over the rear axle housing to the right side member ⇒ *Figure 8-arrow*-.
- 3.1.2 Secure control line for rear axle to the rear axle housing with a fixing clip ⇒ *Figure 8-2*-.
- 3.1.3 Slide control line for rear axle ⇒ *Figure 8-1*- onto the rear silencer control line ⇒ *Figure 8-3*-.

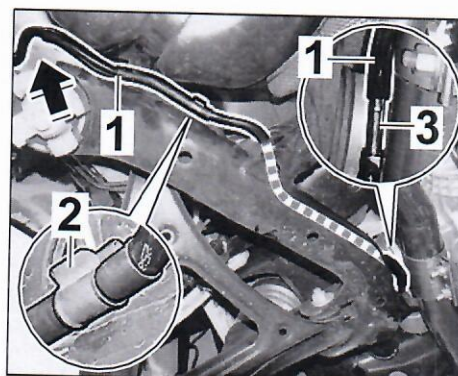

Figure 8

- 3.2 Route control line for door sill.
 - 3.2.1 **Only** for vehicles with levelling system:
Unscrew fastening screws ⇒ *Figure 9-1*- on the compressor and support compressor ⇒ *Figure 9-2*- using suitable devices. ⇒ *Workshop Manual '431519 Removing and installing compressor for the levelling system'*

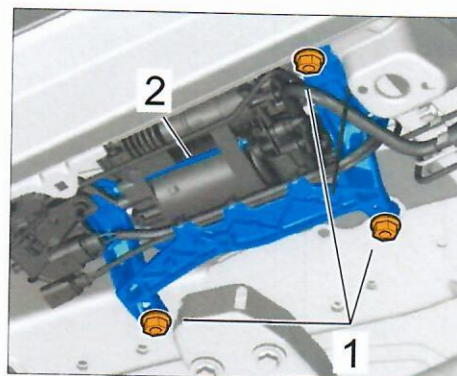

Figure 9

- 3.2.2 Route control line for door sill
⇒ *Figure 10-1*- and clip it in at the existing brake pressure line.

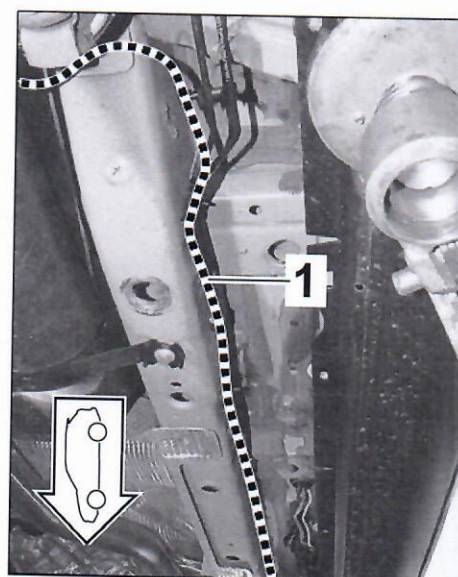

Figure 10

Clip in control line for door sill
⇒ *Figure 11-1*- in the front
wheel housing area at the ex-
isting brake pressure line ⇒
Figure 11-arrow..

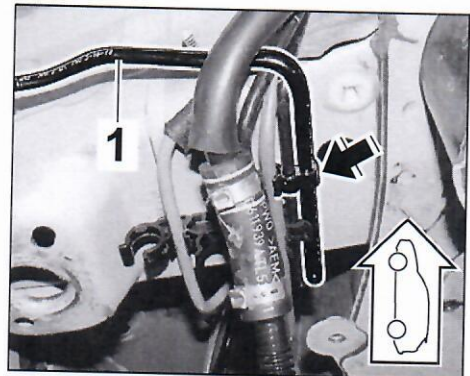

Figure 11

Clip in control line for door sill
in the compressor area at the
existing brake pressure line.

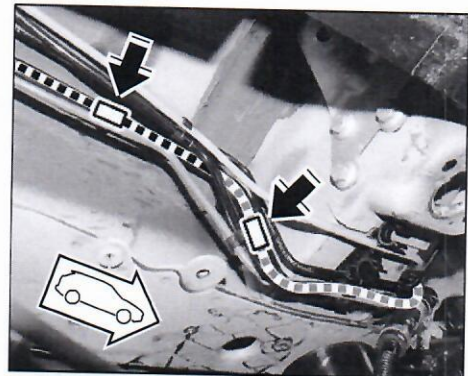

Figure 12

Clip in control line for door sill
⇒ *Figure 13-1*- in the rear axle
housing (chassis subframe)
area at the existing brake pres-
sure lines.

Connect control line for door sill
and control line for rear axle.

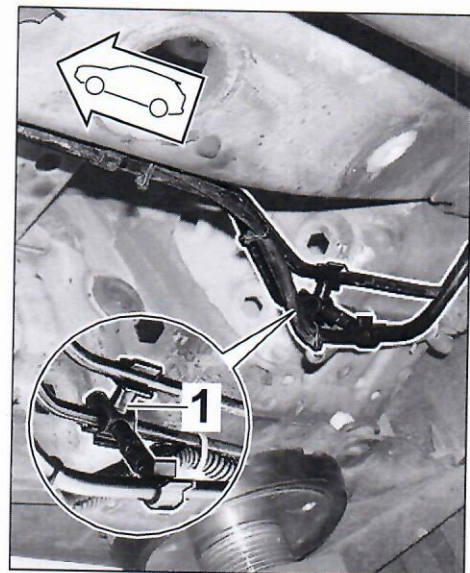

Figure 13

3.3 **Only** for vehicles with levelling system:
Disengage compressor ⇒ *Figure 14-2-*
and tighten fastening screws for com-
pressor ⇒ *Figure 14-1-*.
⇒ *Workshop Manual '4X00IN Tightening
torques for levelling system/Porsche
Dynamic Chassis Control (PDCC)'*

3.4 Route control line for wheel housing.

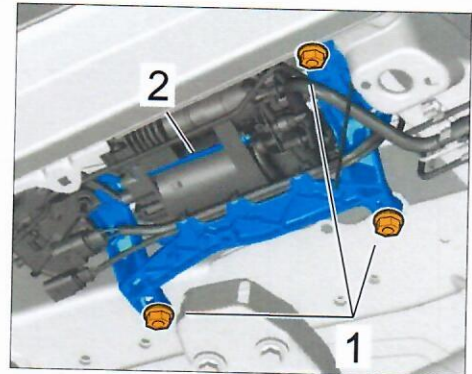

Figure 14

3.4.1 Fit fixing clip ⇒ *Figure 15-2-*
from control valve ⇒ *Figure
15-1-* on the wheel housing ⇒
Figure 15 -arrow-.

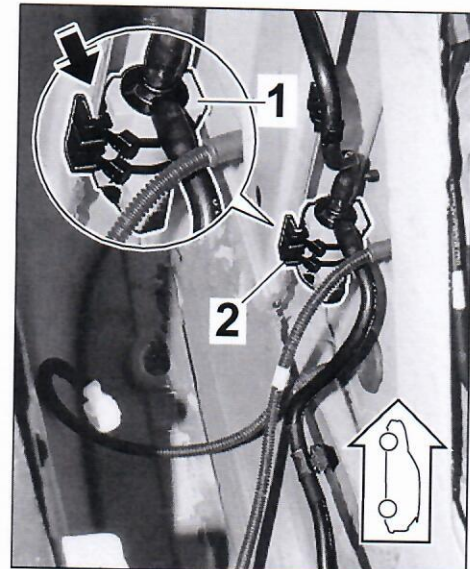

Figure 15

- 3.4.2 Route control line for wheel housing ⇒ *Figure 16-1-* between the wing and wheel housing to the engine compartment ⇒ *Figure 16-B-* and fit fixing clips ⇒ *Figure 16-arrows-*.

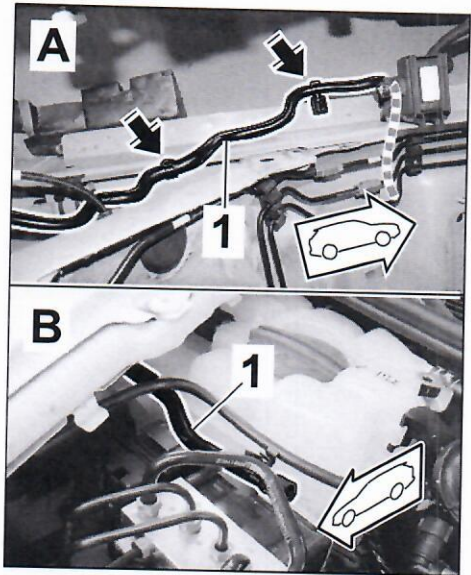

Figure 16

- Fit fixing clips ⇒ *Figure 17-arrows-* on the seam on the wheel housing.

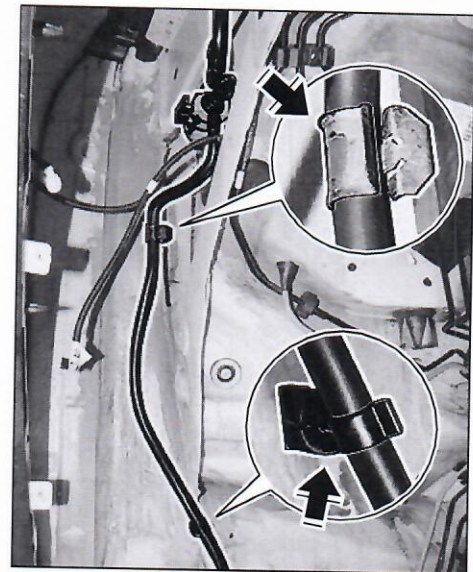

Figure 17

- 3.4.3 Join control line for wheel housing ⇒ *Figure 18-1*- to control line for door sill ⇒ *Figure 18-2*- (⇒ *Figure 18*-arrows-).
- 3.5 **Only** for M5502 = 3.6 litre – Cayenne: Route control line for engine compartment.
- 3.5.1 Pull dummy plug ⇒ *Figure 19-1*- off the Y-piece of the vacuum line.
- 3.5.2 Attach control line for engine compartment to the Y-piece and join it to the control line for the wheel housing.
Clip fixing clip ⇒ *Figure 20-1*- onto the flexible hose ⇒ *Figure 20-2*-.
- 3.5.3 Clip fixing clip for control line for wheel housing onto the vent line.
- 3.6 **Only** for M4802 = 4.8 litre – Cayenne S: Route control line for engine compartment.

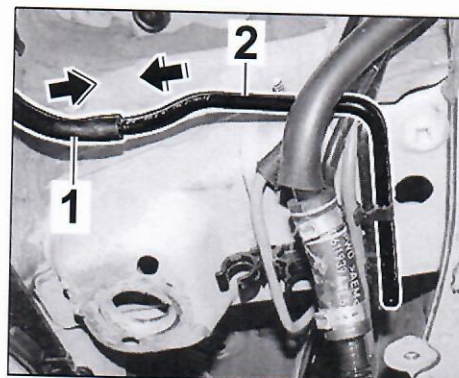

Figure 18

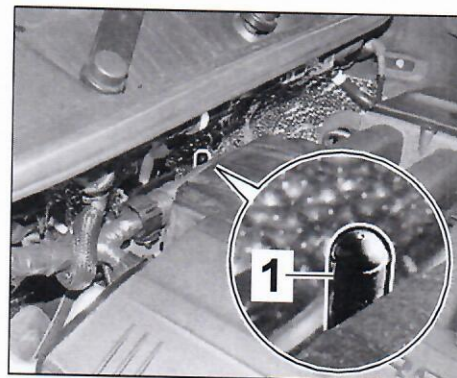

Figure 19

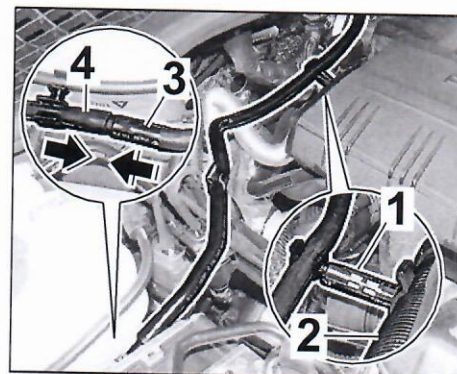

Figure 20

- 3.6.1 Pull dummy plug ⇒ *Figure 21*
-1- off the Y-piece of the vacuum line.

- 1 - Dummy plug
2 - Secondary-air pump



Figure 21

- 3.6.2 Attach control line for engine compartment ⇒ *Figure 22-1-* to the Y-piece and join it to the control line for the wheel housing ⇒ *Figure 22-2-*.

Clip fixing clips for control line for engine compartment ⇒ *Figure 22-inset A and B-* into the vent line.

- 3.6.3 Clip fixing clip for control line for wheel housing into the vent line.

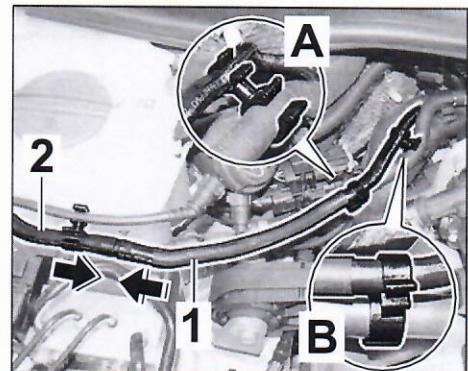

Figure 22

- 4 Install electric wire harness.
- 4.1 **Only** when installing wire harness
958.044.200.05:
Route electric wire harness in the front right wheel housing area.

- 4.1.1 Push connector ⇒ *Figure 23 -3-* onto control valve.
- 1 – Short line end (ground strap)
 - 2 – Long line end (power supply)
- 4.1.2 Route long line end ⇒ *Figure 23 -1-* along the control line for the wheel housing and secure with tie-wraps.

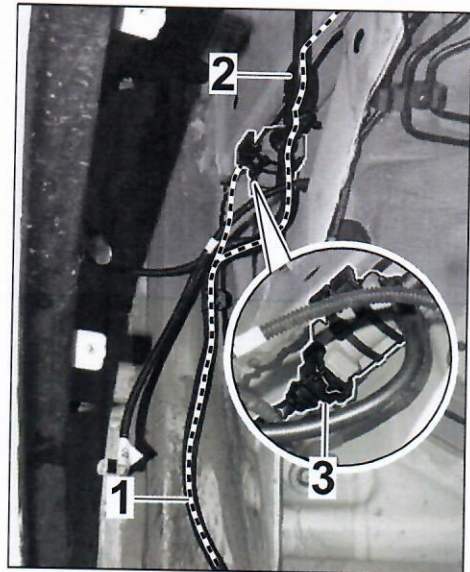

Figure 23

- 4.1.3 Route short line end to front right headlight. Secure short line end ⇒ *Figure 24 -2-* to wheel housing control line ⇒ *Figure 24 -1-* using tie-wraps ⇒ *Figure 24 -arrow-*.



Information

The short line end is secured using a clip on vehicles without Tyre Pressure Monitoring (TPM).

Route short line end behind Tyre Pressure Monitoring (TPM) transmitter holder ⇒ *Figure 24 -3-*.

Secure short line end to side member using clip ⇒ *Figure 24 -4-*.

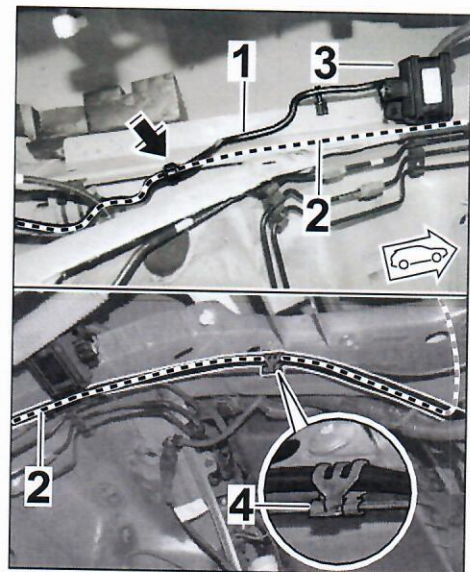

Figure 24

- 4.1.4 Secure ring eyelet to ground point 6 ⇒ *Figure 25-1-* (side member).

Tightening torque 9 Nm

- 4.2 **Only** when installing wire harness 958.044.200.04:
Route electric wire harness in the front right wheel housing area.

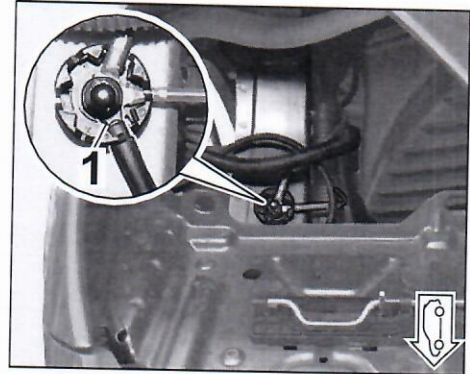

Figure 25

- 4.2.1 Push connector ⇒ *Figure 26-2-* onto control valve.
- 4.2.2 Route electric wire harness ⇒ *Figure 26-1-* along the control line for the wheel housing and secure with tie-wraps.
- 4.2.3 Secure ring eyelet to ground point ⇒ *Figure 26-3-*. **Tightening torque 9 Nm**

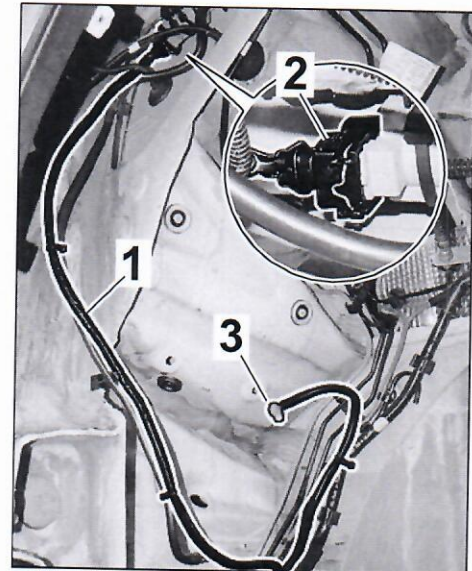

Figure 26

4.3 Route electric wire harness in the door sill area.

4.3.1 **Only** for vehicles with levelling system:
Secure electric wire harness ⇒ *Figure 27-1*- to the compressor ⇒ *Figure 27-2*- using a tie-wrap.

4.3.2 Route electric wire harness ⇒ *Figure 27-1*- along the control line for the door sill and secure with tie-wraps.

4.4 Route electric wire harness in the rear wheel housing area.

4.4.1 Route electric wire harness ⇒ *Figure 28-1*- in the rear wheel housing area and secure to the existing lines with tie-wraps.

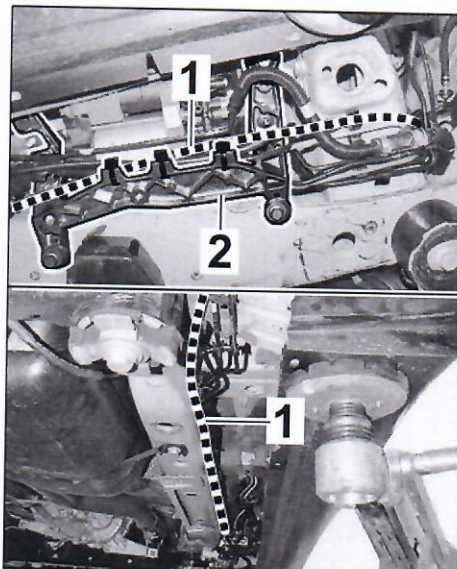

Figure 27

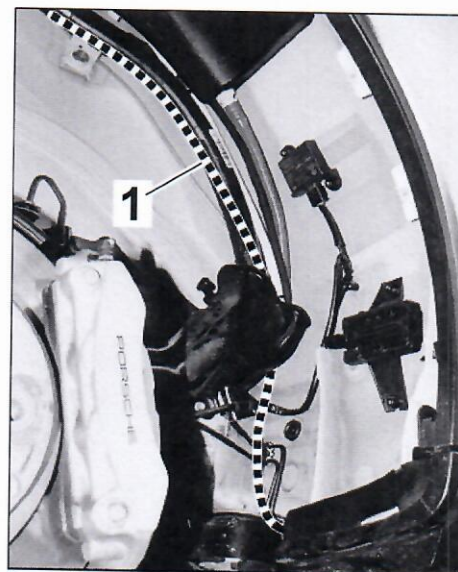

Figure 28

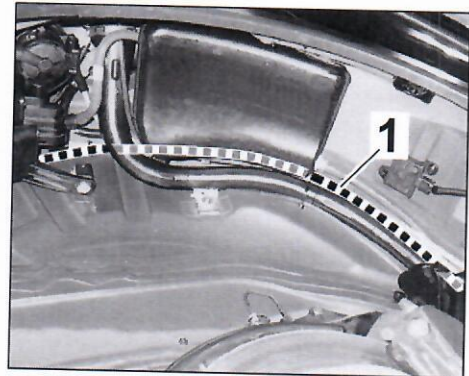

Figure 29

- 4.4.2 Punch rubber sleeve \Rightarrow Figure 30-2- and guide electric wire harness \Rightarrow Figure 30-1- into the passenger compartment.

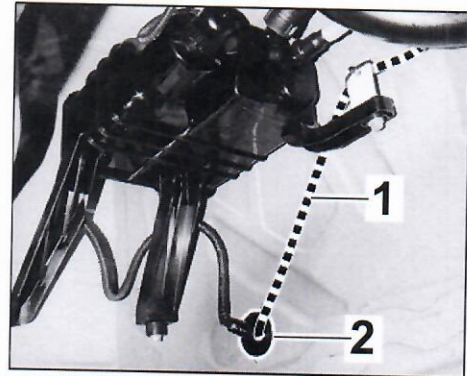

Figure 30

- 4.5 Route electric wire harness \Rightarrow Figure 31-1- to the rear-end electronics control unit \Rightarrow Figure 31-2- and secure it to the standard electric wire harness with tie-wraps.
- 4.6 Connect electric wire harness to the rear-end electronics control unit.

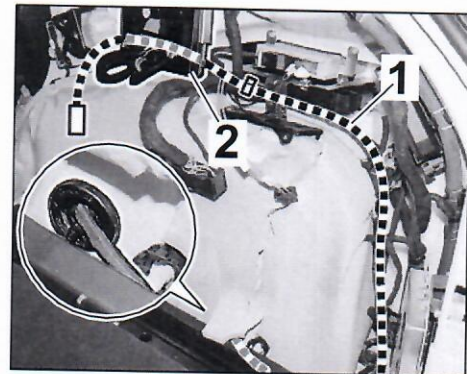

Figure 31

- 4.6.1 Press down the locking mechanism ⇒ *Figure 32 -arrow-* and swivel the clip ⇒ *Figure 32 -1-* upwards. Disconnect electric plug connection ⇒ *Figure 32 -2-*.

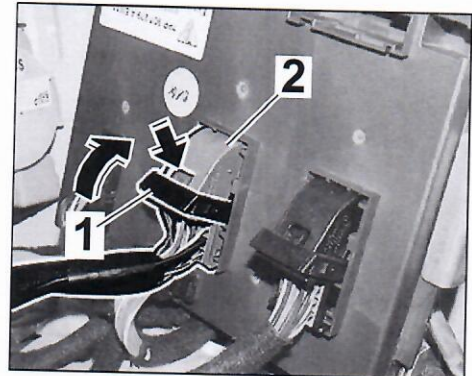

Figure 32

- 4.6.2 Press down the locking mechanism ⇒ *Figure 33 -arrow-* and slide the grey plug socket ⇒ *Figure 33 -1-* out of the plug carrier ⇒ *Figure 33 -2-*.

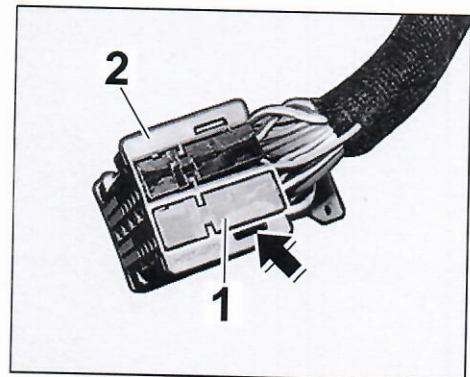

Figure 33



Information

Ensure socket contact is seated securely.

- 4.6.3 Insert socket contact ⇒ *Figure 34 -1-* into chamber A2 of the grey plug socket ⇒ *Figure 34 -2-*.

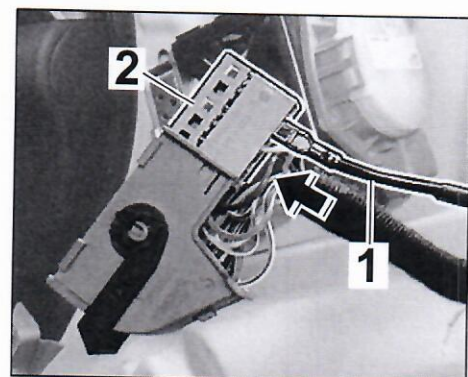

Figure 34

- 4.6.4 Slide grey plug socket ⇒ *Figure 35-1-* into the plug carrier ⇒ *Figure 35-2-* until the locking mechanism ⇒ *Figure 35-arrow-* engages.

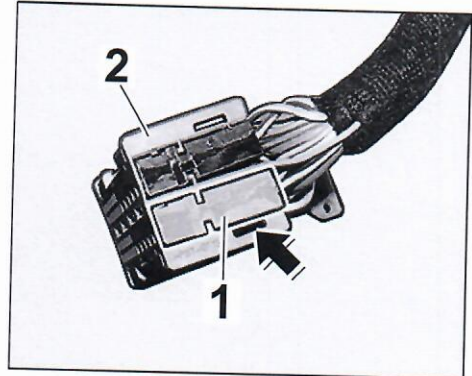

Figure 35

- 4.6.5 Connect electric plug connection ⇒ *Figure 36-2-* and swivel the clip ⇒ *Figure 36-1-* down.
- 4.7 Seal rubber sleeve with adhesive compound.

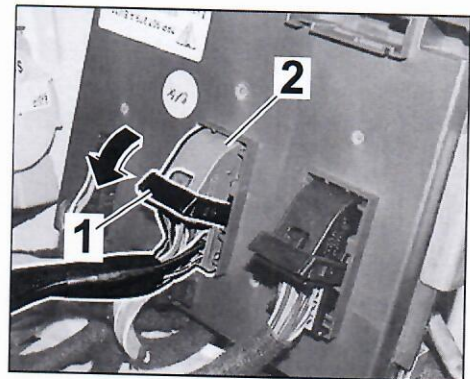

Figure 36

5 Concluding work:

- 5.1 Install loudspeaker booster. ⇒ *Workshop Manual '914419 Removing and installing loudspeaker booster'*
- 5.2 Install centre cover at the right. ⇒ *Workshop Manual '519319 Removing and installing centre cover'*
- 5.3 Install reservoir for windscreen washer system. ⇒ *Workshop Manual '926019 Removing and installing reservoir for windscreen washer system'*
- 5.4 Install front right wheel housing liner. ⇒ *Workshop Manual '505619 Removing and installing front wheel housing liner'*
- 5.5 Install rear wheel housing liner at the right. ⇒ *Workshop Manual '536919 Removing and installing rear wheel housing liner'*
- 5.6 Fit right front wheel and right rear wheel. ⇒ *Workshop Manual '440519 Removing and installing wheel'*

- 5.7 Screw in fastening screw ⇒ *Figure 37* **-arrow-** on the filler tube for the wind-screen washer system reservoir.
- 5.8 Install engine compartment trim panel at the right. ⇒ *Workshop Manual '700219 Removing and installing front trim (engine compartment)'*
- 5.9 **Only** when installing wire harness 958.044.200.05: Install front right headlight. ⇒ *Workshop Manual '941519 Removing and installing headlights'*

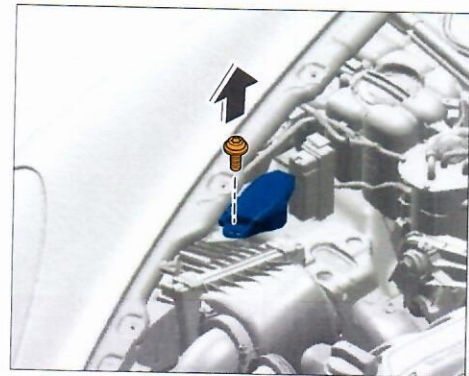

Figure 37

- 6 **Only** for vehicles from model year 2014 onwards: Remove standard strip for switches and install new strip for switches. ⇒ *Workshop Manual '431019 Removing and installing levelling system (selector switch)'*

NOTICE

Voltage drop

- Risk of irreparable damage to control unit
 - Risk of damage to control unit
 - Fault entries in the control unit
 - Coding in the control unit is aborted
 - Malfunctions in control unit, even during programming
- ⇒ Prior to disconnecting the control unit, switch off ignition and remove ignition key.
- ⇒ Ensure that the power supply is not interrupted during programming.
- ⇒ Connect a battery charger with a current rating of at least 90 A to the vehicle battery.



Information

The **9900 - PIWIS Tester 3** instructions take precedence since the description may be different with later Tester releases.

The procedure described here has been structured in general terms. Different text or additional information may appear in **9900 - PIWIS Tester 3**.

- 7 Code sports exhaust system.
 - 7.1 **9900 - PIWIS Tester 3** must be connected before switching on the ignition.
 - 7.2 Select the required vehicle type. PIWIS Tester II Diagnostics starts.
 - 7.3 Maintenance of vehicle data.
 - 7.3.1 Select Additional menu by pressing •F7 ". Press •F11 " to confirm the question "Create Vehicle Analysis Log (VAL)?".

- 7.3.2 Select the "Maintenance of vehicle data" function. Press •F12 " until "PR numbers" appears in the Value group column.
- 7.3.3 Select "Exhaust tailpipe" in the Family column.
Open the submenu in the Value column and select "OP8 - Sports exhaust system". Press •F12 " to continue.
- 7.3.4 The selected values appear. Press •F8 " to write values. Wait until the message "Generation of vehicle data is complete. to continue." appears.
- 7.3.5 Press •F12 " to switch to Log management. Open the log by pressing •F10 " and check that vehicle equipment "OP8 - Sports exhaust system" has been entered. Close the log.
Press •F11 " to switch to the control unit overview.
- 7.4 Adapt coding.
- 7.4.1 Select all control units with •Ctrl A ".
Switch to the "Codings/adaptations" menu.
- 7.4.2 Select "Automatic coding". Press •F12 " to continue.
- 7.4.3 Wait until "Coding was completed successfully" appears. Press •F12 " to continue.
Switch to the **Overview** menu.
- 7.5 Read out the fault memories of all systems, work through any existing faults and erase the fault memories. ⇒ *Workshop Manual '0335IN Diagnostic maintenance: diagnostic system and maintenance inter...'*
- 7.6 Switch off ignition and disconnect **9900 - PIWIS Tester 3**.
- 8 Disconnect battery charger. ⇒ *Workshop Manual '2X00IN Battery trickle charging'*

26 01 31 00: –Converting exhaust system–
Includes: Replacing rear silencers, routing and connecting control lines and electric wire harness, removing and installing loudspeaker booster, front and rear wheel housing liner, underbody covers, right wheels, right headlight. Labor time: **490 TU**

43 10 19 00: **ONLY** for vehicles from model year 2014 onwards:
–Removing and installing selector switch– Labor time: **75 TU**